

HIGH END SYSTEMS

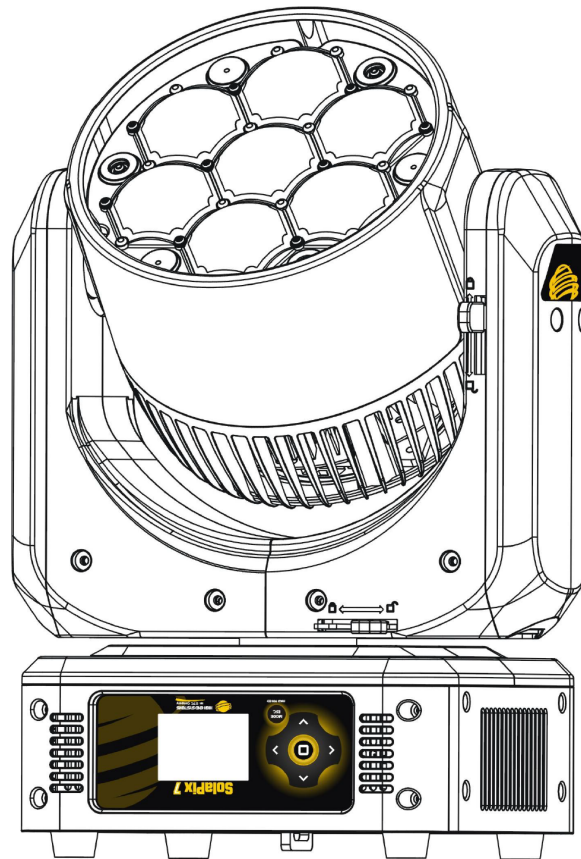

an ETC. Company



SolaPix 7

Automated Luminaire
User Manual

Version 1.2 — Revision A



To view a list of ETC trademarks and patents, go to etconnect.com/ip. All other trademarks, both marked and not marked, are the property of their respective owners.

Information and specifications in this document are subject to change without notice.

Table of Contents

- Introduction 1
 - Contacting High End Systems 1
 - Headquarters 1
 - Technical Support 1
 - FCC Information 1
 - Patents 1
 - Terms and Conditions and Warranty Information 2
 - Product Modification Warning 2
 - Mise En Garde Contre La Modification Du Produit 2
 - Produktmodifikationswarnung 2
 - Avvertenza Sulla Modifica Del Prodotto 2
 - Advertencia De Modificación Del Producto 2
 - Declaration of Conformity 3
 - Important Safety Information 4

- Fixture Overview 5
 - Modular Control 6
 - Dimensions 7

- Safety Considerations 8
 - General Operation and Use Guidelines 9

- Install the Fixture 10

- Power 12
 - Input and Power Factor 12
 - Connector Specification 12

DMX Control	13
DMX Connector Pinout	13
Connect DMX Cables to Fixture	13
Terminate DMX	14
Set the DMX Start Address	14
DMX Channels	14
Ethernet Control	15
Connect Ethernet Cables to a Fixture	15
Set the DMX Start Address	16
Set the Control Source and Universe	16
Configure the Fixture	17
Navigate the User Interface	17
Set Fixture Parameters	18
Address	18
Info Menu	22
Set Menu	24
Test Menu	27
Preset Menu	27
Error Codes	30
Cleaning and Maintenance	31

Introduction

Congratulations on your purchase of the SolaPix 7 automated fixture. This manual provides important information for the safe installation, configuration, and maintenance of your SolaPix 7 fixture.

Contacting High End Systems

High End Systems, Inc. is an ETC company.

Headquarters

For Customer Service or Sales support, please contact our company headquarters:

2105 Gracy Farms Lane

Austin, TX 78758 USA

Tel: 512.836.2242

Fax: 512.837.5290

Toll-free: 800.890.8989

Website: highend.com

Technical Support

If you are having difficulties installing, configuring, or operating your SolaPix 7, your most convenient resources are the references given in this manual. To search more widely, try the High End Systems, Inc. website at highend.com. Additional technical resources are available on the support website support.etcconnect.com/HES.

If you have additional questions that cannot be answered within these resources, contact High End Systems Technical Services directly at the office nearest you. Emergency support is available outside of regular business hours. Contact information is available at highend.com/about/contact-us.

FCC Information

This equipment has been tested and found to comply with the limits for a Class A digital device, pursuant to part 15 of the FCC rules. These limits are designed to provide reasonable protection against harmful interference when the equipment is operated in a commercial environment. This equipment generates, uses, and can radiate radio frequency energy and, if not installed and used in accordance with the instruction manual, may cause harmful interference to radio communications. Operation of this equipment in a residential area is likely to cause harmful interference, in which case the user will be required to correct the interference at his own expense.

Patents

NOTICE OF INTELLECTUAL PROPERTY RIGHTS

High End Systems, Inc. products are protected by one or more patents listed on the High End Systems, Inc. website: <https://www.highend.com/patents> and/or are subject to one or more pending patents.

Terms and Conditions and Warranty Information

Complete terms and conditions and warranty information can be found on the High End Systems, Inc. website: <https://www.highend.com/pub/products/HES-Warranty-Information.pdf>.

Product Modification Warning

High End Systems products are designed and manufactured to meet the requirements of the United States and International safety regulations. Modifications to the product could affect safety and render the product non-compliant to relevant safety standards.

Mise En Garde Contre La Modification Du Produit

Les produits High End Systems sont conçus et fabriqués conformément aux exigences de règlements internationaux de sécurité. Toute modification du produit peut entraîner sa non conformité aux normes de sécurité en vigueur.

Produktmodifikationswarnung

Design und Herstellung von High End Systems entsprechen den Anforderungen der U.S. Amerikanischen und internationalen Sicherheitsvorschriften. Abänderungen dieses Produktes können dessen Sicherheit beeinträchtigen und unter Umständen gegen die diesbezüglichen Sicherheitsnormen verstoßen.

Avvertenza Sulla Modifica Del Prodotto

I prodotti di High End Systems sono stati progettati e fabbricati per soddisfare i requisiti delle normative di sicurezza statunitensi ed internazionali. Qualsiasi modifica al prodotto potrebbe pregiudicare la sicurezza e rendere il prodotto non conforme agli standard di sicurezza pertinenti.

Advertencia De Modificación Del Producto

Los productos de High End Systems están diseñados y fabricados para cumplir los requisitos de las reglamentaciones de seguridad de los Estados Unidos e internacionales. Las modificaciones al producto podrían afectar la seguridad y dejar al producto fuera de conformidad con las normas de seguridad relevantes.

Declaration of Conformity



Declaration of Conformity

Manufacturer's name: HAO YEANG ELECTRONIC CO., LTD
Manufacturer's address: No. 109, HaiYong Road, GuanNanYoung Industry Districe, Shiji Town
DanYu Zone, GuanZhou City, China

Distributor's name: High End Systems, Inc.
Distributor's address: 2105 Gracy Farms Lane
Austin, Texas 78758 USA

Product Name: SolaPix 7, SolaPix19
Product Options: All

We hereby declare that the above referenced product complies with the essential requirements of Council Directives 2014/30/EU (EMC), 2014/35/EU (LVD) and 2011/65/EC (RoHS) .

Safety: EN 60598-1: 2015 + A1:2018
EN 60598-2-17: 2018: 1991
EN62493 (2015)
EN62031:2008 +A1:2013 +A2:2015
EN62471 (2008)
EN61347-2-11: 2001;
EN61347-1: 2015

High End Systems | 2105 Gracy Farms Lane | Austin TX 78758 | highend.com

Important Safety Information

Please read all instructions prior to assembling, mounting, and operating this equipment. Continued and safe operation of this fixture is the responsibility of the operator. This manual will give tips for that continued safe operation. At any time please contact High End Systems technical support for any safety concerns.

The following international note, caution, and warning symbols appear in margins throughout this manual to highlight important messages.



Note: *Notes are helpful hints and information that is supplemental to the main text.*



CAUTION: *This statement indicates that while operating, equipment surfaces may reach very high temperatures. Allow the fixture to cool before handling or servicing.*



CAUTION: *A Caution statement indicates situations where there may be undefined or unwanted consequences of an action, potential for data loss or an equipment problem.*



WARNING: *A Warning statement indicates situations where damage may occur, people may be harmed, or there are serious or dangerous consequences of an action*



WARNING: RISK OF ELECTRIC SHOCK! *This warning statement indicates situations where there is a risk of electric shock.*

Fixture Overview

For technical specifications of the SolaPix 7 fixture, see the technical data sheet:

<https://www.highend.com/documentation/SolaPix7/SolaPix7-Datasheet.pdf>

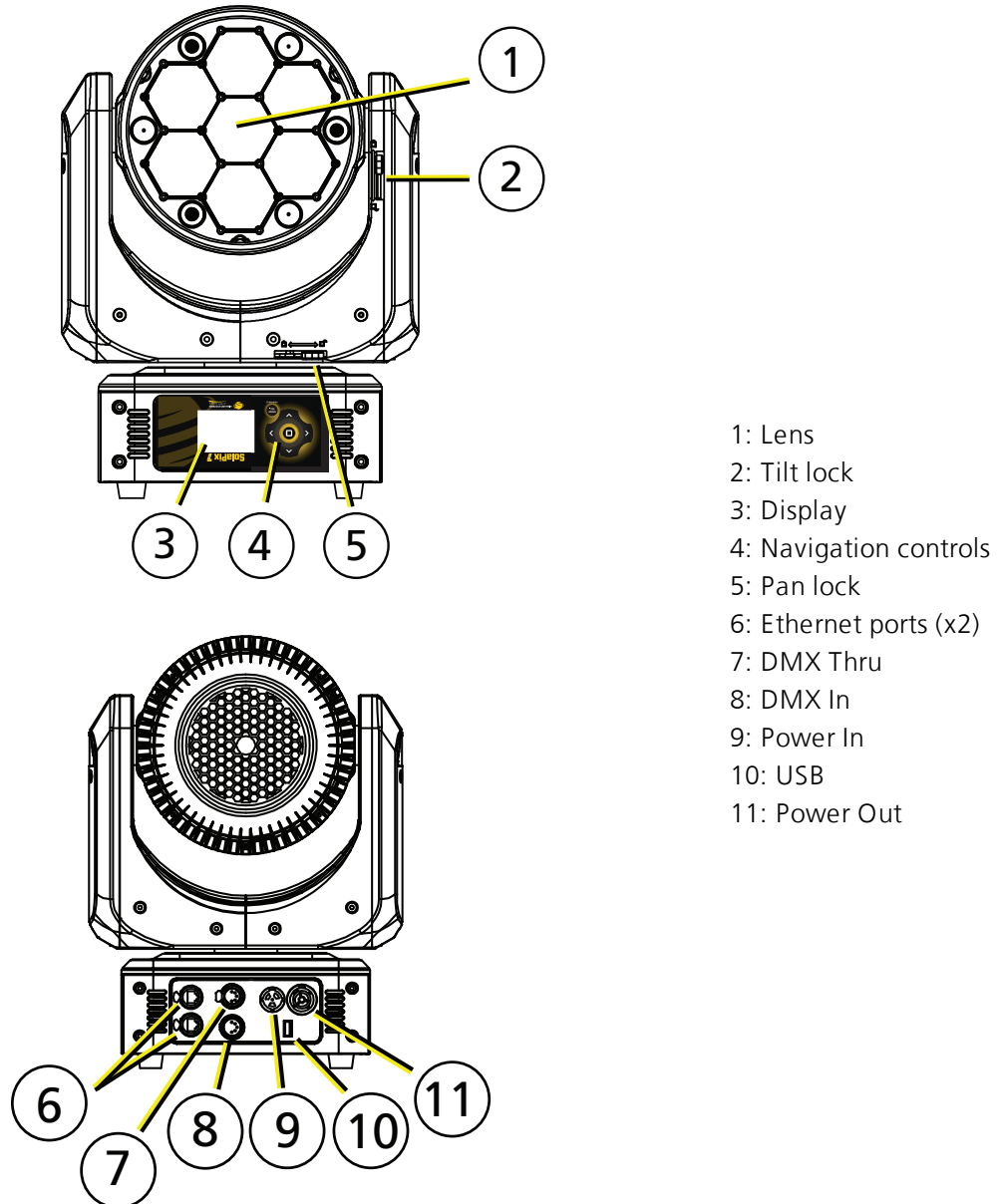

Modular Control

The SolaPix 7 fixture has three segments of control (or modules) that essentially give you three fixtures in one, letting you customize each fixture based on your control needs.

- The Base module is the master. The settings in this module control the basic functions of the fixture, which include pan, tilt, zoom, and the control settings for the fixture.
- The Macro (Flex) module lets you build and customize animation effects based on a library of animations.
- The Pixel module gives you individual control of each pixel.

The Base module is always active. The Macro (Flex) and Pixel modules can be disabled, or they can be set to Compound or Independent modes.

In Compound mode, a module automatically addresses itself to the same source as the Base module and follows immediately after the address of the Base module.

In Independent mode, you address a module individually to any source (DMX or Ethernet), Address, or Universe that your control setup requires.

Compounding the modules enables several different options:

- Base + Flex (default)
- Base + Pixel
- Base + Flex + Pixel

See [Configure the Fixture on page 17](#) for information about configuring the modules.

Because the modules all control the same light sources, you can set the priority of control using the Module Priority function (channel 11 in the Base module).

See the DMX map on the High End Systems, Inc. website for details.

<https://www.highend.com/documentation/SolaPix7/SolaPix7-protocol.pdf>

Dimensions

Dimensions shown are listed as inches [millimeters].

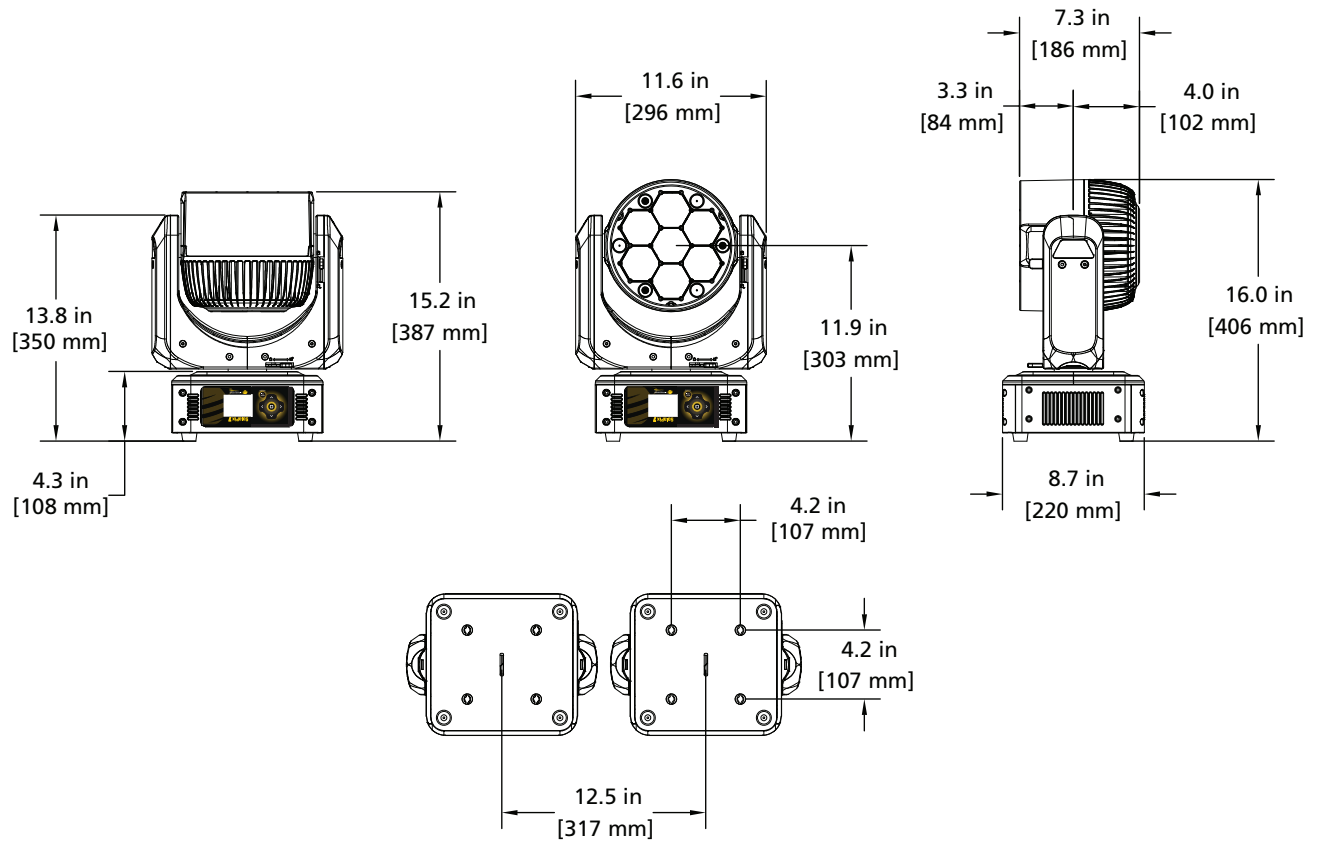

Safety Considerations

In order to ensure safe operation, follow the safety instructions and warning notes in this user manual and any instructions from the manufacturer representative.

- The SolaPix 7 fixture is intended for professional use only. Not for residential use. Read the entire manual before using this equipment.
 - Contact your High End Systems dealer or High End Systems technical support before performing any service in order to maintain warranty coverage.
-



WARNING: For your safety, read the following warnings and notices before use:

- This equipment is designed for operation by qualified personnel only.
 - Disconnect the unit from power and DMX and data before servicing.
 - Replace fuses with the specified type and rating only.
 - Make sure that the available voltage is within the stated range. See [Power on page 12](#).
 - NEMA Type 1 enclosure, indoor use, dry locations only. Do not use outdoors. This fixture is intended for use where humidity does not exceed 90% (non-condensing).
 - Do not use this fixture with a damaged power lead (cord set). If the lead is damaged, it must be replaced by a qualified technician with an equivalent type before use. Contact your local authorized dealer for spare power leads.
 - Do not use this fixture if the lens is damaged. Damaged lenses must be replaced before use. Contact your local authorized dealer for a replacement.
 - When the fixture has been stored or transported in cold temperatures, allow it to warm to room temperature for a minimum of one hour before applying power. Applying power to a cold fixture may cause damage to the fixture and void the manufacturer warranty.
 - This is a Class 1 device and must be grounded. Follow national and local codes.
 - Do not project the beam onto combustible substances.
 - Keep fixture head at least 0.1 m (0.33 ft) away from any flammable materials.
 - Minimum distance to lighted objects: 1 m (3.28 ft).
 - When you power on the fixture, you may notice smoke or odor. This is normal and should decrease gradually. If smoke or odor persists, disconnect the fixture from power and contact your High End Systems dealer or High End Systems technical support.
-



CAUTION: *Hot Surfaces. Allow the fixture to cool completely before handling and servicing.*



CAUTION: *Damages caused by the disregard of this user manual are not subject to warranty. High End Systems, Inc. and its authorized dealers will not accept liability for any resulting defects or problems.*

General Operation and Use Guidelines

- This fixture is only allowed to be operated with the maximum alternating current that is stated in the technical specifications label provided on the fixture.
- Lighting effects are not designed for permanent operation. Consistent operation breaks may ensure that the fixture will serve you for a long time without defects.
- Do not shake the fixture. Avoid brute force when installing or operating the fixture.
- When choosing the installation location, make sure that the fixture is not exposed to extreme heat, moisture, or dust.
- If using the supplied Omega brackets with quick-locking thumb screws for fixture hanging, ensure that the thumb screws have engaged a complete 90-degree positive latch.
- Operate the fixture only after having familiarized yourself with its functions. Do not permit other persons who are not qualified and familiar with its functions to operate the fixture.
- Please use the original packaging if the fixture is to be transported. ETC and High End Systems, Inc. will not be responsible for the fixture if packaging other than manufacturer provided packaging is used.
- Do not modify the fixture. Any modifications will void the warranty.
- This manual describes the proper installation and operation of this fixture. Using this fixture in any way other than the intended use may cause damage and may void the warranty.
- Misuse of this fixture or using it in a way different from the methods described in this manual may lead to personal injury and/or equipment failure.
- The light source of this fixture is not replaceable. When the light source reaches its end of life, replace the fixture.

Install the Fixture



WARNING:

- The installation location must support a minimum point load of 10 times the weight of the fixture.
 - The installation must always be secured with a secondary safety attachment. An appropriate safety cable is supplied.
 - Safety cable attachment must be rated by a safety factor of 10.
 - Use of third party clamps are permitted, but they should comply with, and be approved by, the Authority Having Jurisdiction (AHJ).
 - A supportive and stable surface must be used when the fixtures are placed on the feet.
 - The operating temperature range for this fixture is -10°C – 45°C (14°F – 113°F). Do not operate the fixture outside of this range.
 - Never stand directly below the installed fixture when mounting, removing, or servicing the fixture.
 - All safety and technical aspects of fixture installation must be approved by a qualified personnel before operation.
 - The installation must be regularly inspected by qualified personnel.
 - Overhead rigging must be performed by qualified personnel.
-



CAUTION: *Follow all local codes and recommended practices by the Authority Having Jurisdiction. The installation must only be carried out by qualified personnel.*

You can install the fixture in any of the orientations shown below.

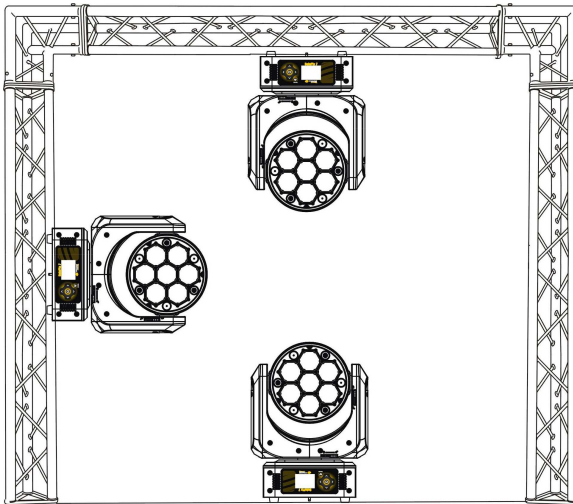

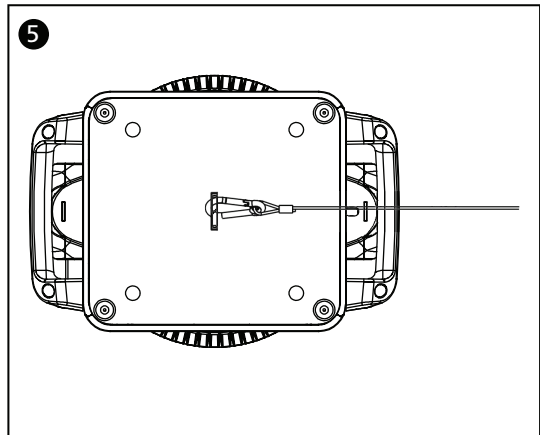
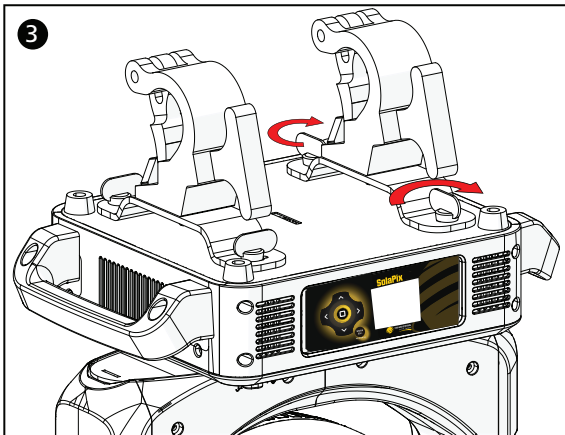
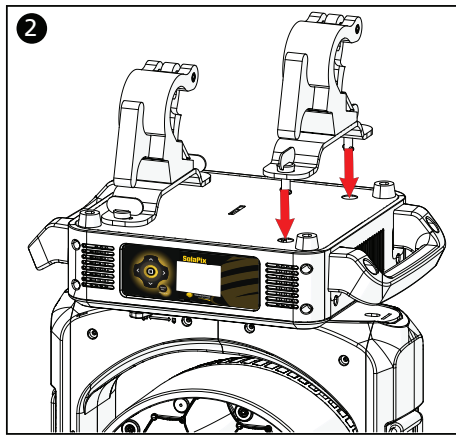
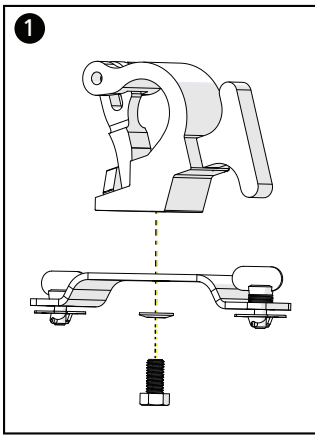

1. Assemble the clamp (provided by others) to the Omega bracket and secure together using appropriately sized hardware (not provided).
2. Align the assembled Omega bracket and quick-lock fasteners into the respective holes on the bottom of the fixture upper enclosure.
3. Tighten each of the quick-lock fasteners fully, turning clockwise. You will hear and feel a click when the fastener is fully secured.
4. Repeat steps 1 through 3 for the second clamp and bracket.
5. Attach the provided safety cable through the attachment point on the bottom of the fixture upper enclosure and secure to the trussing system or other safe installation point. Follow local codes and recommended safety standards for securing the fixture to the installation location.
6. Attach the fixture to the installation location using the installed clamps, using the clamp manufacturer's instructions for a secure fit. When using the Omega clamp, close the safety and fully tighten the clamp wing nut until secure.
7. Inspect the installation prior to lifting the fixture overhead.

Power

Input and Power Factor

VAC	Amps	Hz	Watts	VA	PF
100	4.1	50	408	411	0.99
120	3.4	60	400	405	0.99
200	2.0	50	388	399	0.97
208	2.0	60	388	410	0.96
220	1.8	50	385	400	0.96
240	1.7	60	382	406	0.94



CAUTION: *Using this fixture below 100 V on a 15 A breaker may cause the breaker to trip. Ensure that the circuit can handle the fixture's maximum potential draw before you connect it.*

Connector Specification

A fixture power cord with powerCON TRUE1 input to bare end is provided. Install a suitable connector to meet the installation requirements. See the following wire color code chart:

Wire Color Code (EU)	Wire Color Code (US Standard)	Connection type	Terminal
Green/Yellow	Green	Earth/Ground	
Blue	White	Neutral	N
Brown	Black	Line (Live)	L



WARNING: RISK OF ELECTRIC SHOCK! The powerCON TRUE1 is a connector system consisting of the cable connector and the chassis receptacle. A cable connector inserted the incorrect way could, in some circumstances, lead to contact between live wires and the grounding contact in the plug socket resulting in equipment malfunction and/or personal injury.

Check the condition of your powerCON TRUE1 connector system (cable connector and chassis receptacle) for clear signs of wear and tear.

Reference the [Neutrik Safety Notice powerCON TRUE1](#) for more safety information.

DMX Control

The SolaPix 7 fixture operates on standard DMX-512 control bus, controlled by a DMX console. The fixture requires 63 channels of DMX-512 in standard mode.

Attach the fixture to the control bus using a two-core, shielded cable with a 5-pin XLR connector (Belden 9729 is preferred).

Two XLR termination receptacles are available: one for connection of DMX Input, and one for DMX Thru (used when daisy-chaining to additional fixtures on the DMX control bus).

DMX Connector Pinout

For DMX Input, the DMX cable must have a male XLR connector on one end of the cable that connects to the fixture. When daisy-chaining DMX to the next device, prepare a DMX cable with a female XLR connector on one end and a male XLR connector on the other end. Terminate the cable ends as indicated in the pinout image below.

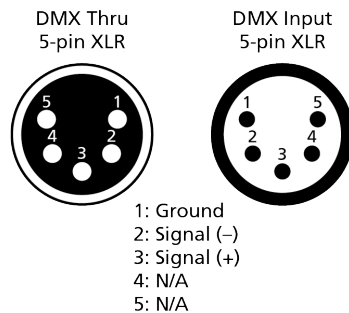

Connect DMX Cables to Fixture

The following instructions are guidelines for connecting DMX to your fixture. Your installation may vary.

1. Connect the male XLR connector of a DMX data cable to the DMX Thru connector on the DMX control source.
2. Connect the female XLR connector of the DMX data cable to the DMX In connector of the first fixture on the DMX control run.
3. Continue linking the remaining fixtures by connecting a cable from the DMX Thru connector of a fixture to the DMX In connector of the next fixture on the control run.



Note: A maximum of 32 DMX devices may be connected in any one DMX data run when installed in a daisy-chain fashion.

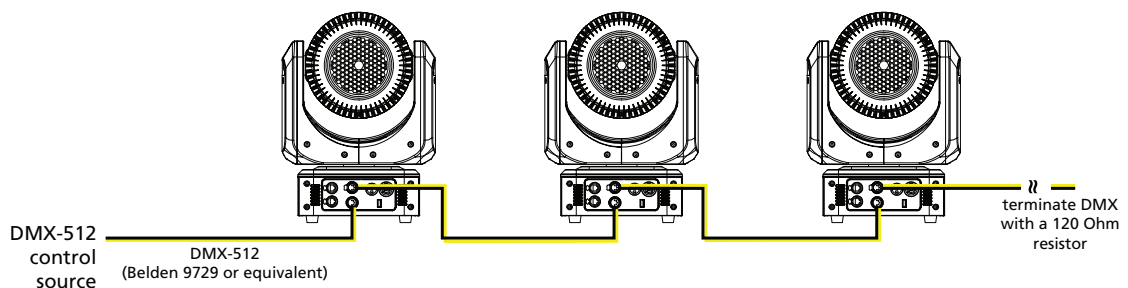

Terminate DMX

Use a DMX terminator or install a resistor on the last fixture of the DMX control run to prevent corruption (data reflection) of the digital control signal by electrical noise.

A DMX terminator is an XLR plug with a 120 Ω resistor connected between pins 2 and 3 that can be installed into the DMX output receptacle of the last fixture in the DMX control run. This plug is available and sold separately. Contact your local High End dealer for ordering information (visit highend.com/about/contact-us to locate a High End dealer).

Set the DMX Start Address

Give each fixture a unique DMX starting address so that the correct fixture responds to the control signals. This DMX start address is the channel number from which the fixture starts to “listen” to the digital control information sent out from the control source.

Modify the fixture DMX start address on the user interface, located on the upper enclosure. See [Address on page 18](#).



Example: The SolaPix 7 requires up to 63 channels of control depending on the configuration of the modules. The Base module uses 20 channels. When the Macro (Flex) module is set to Compound mode, an additional 15 channels are added. If the Pixel module is also set to Compound mode, then an additional 28 channels are added, making 63 channels total.

If you are using the Base and Pixel modules (the Pixel module is set to Compound mode and the Macro (Flex) module is disabled) the total channel usage is 48 channels.

DMX Channels

The most current DMX Map data for the SolaPix 7 can be found on the High End Systems, Inc. website:

<https://www.highend.com/documentation/SolaPix7/SolaPix7-protocol.pdf>

Ethernet Control

The SolaPix 7 fixture includes two Ethernet ports that allow sending and receiving of control signals using the Art-Net protocol or sACN.

Use a Cat5e (or better) cable and terminate to RJ45 connectors following the TIA/EIA 568B wiring standard.

Connect Ethernet Cables to a Fixture

The following instructions are guidelines for connecting Ethernet to your fixture. Your installation may vary.

1. Connect a cable from the Ethernet control source to one of the Ethernet ports on the first fixture in the Ethernet control run.
2. Connect the first fixture to a second fixture by connecting a cable from the second Ethernet port on the first fixture to one of the Ethernet ports on the second fixture.
3. Continue linking the remaining fixtures by connecting a cable from Ethernet port to Ethernet port on the fixtures on the control run.



Note: *The Cat5e cable distance should not exceed 100 m, and you should not connect more than 20 fixtures in one Ethernet control run when the fixtures are linked together.*

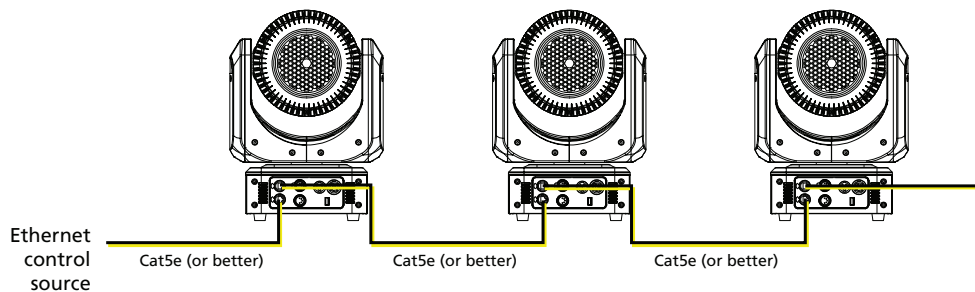

Set the DMX Start Address

Give each fixture a unique DMX starting address so that the correct fixture responds to the control signals. This DMX start address is the channel number from which the fixture starts to “listen” to the digital control information sent out from the control source.

Modify the fixture DMX start address on the user interface, located on the upper enclosure. See [Address on page 18](#).



Example: The SolaPix 7 requires up to 63 channels of control depending on the configuration of the modules. The Base module uses 20 channels. When the Macro (Flex) module is set to Compound mode, an additional 15 channels are added. If the Pixel module is also set to Compound mode, then an additional 28 channels are added, making 63 channels total.

If you are using the Base and Pixel modules (the Pixel module is set to Compound mode and the Macro (Flex) module is disabled) the total channel usage is 48 channels.

Set the Control Source and Universe





For Ethernet control, you must configure the control source (Art-Net or sACN) and set a universe (000-255) for each fixture. See [Address on page 18](#) for details.

Configure the Fixture

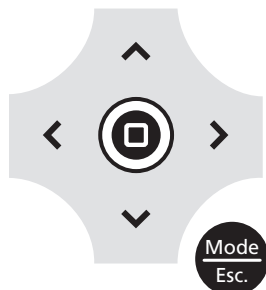
You can configure SolaPix 7 fixtures through the onboard user interface.

Navigate the User Interface



1. Press the [MODE/ESC] button () to access the main menu. (The display is powered by battery when the fixture has no power.)
2. Browse the menu by pressing the up, down, left, or right navigation buttons.
3. Press the [Enter] button () to select a menu item.
4. Modify the selection by pressing the up, down, left, or right navigation buttons according to the selection.
5. Press the [Enter] button () to confirm a modified selection.
6. To exit the menu, press the [MODE/ESC] () button.



Note: *If you press the [Enter] button to confirm a selection and push no other buttons, the user interface returns to the default display after 15 seconds.*

Set Fixture Parameters

This section provides instructions to configure and set up the SolaPix 7. See [Navigate the User Interface on the previous page](#) for information about the navigation buttons.

Provide power to the fixture before configuring it. If you do not provide power, the fixture will use battery power to power the user interface.

Address

Navigate: Main Menu → Address

The Address menu provides access to configure the three modules: Base, Macro (Flex), and Pixel. You can configure each module individually, or you can compound some or all of the modules. For information about the modules, see [Modular Control on page 6](#).

Navigate: Main Menu → Address → Base Module

Base module configuration is mandatory. You must configure this module for each fixture.

Settings	Value	Description
Source	<ul style="list-style-type: none">• DMX• Art-Net• sACN	Select the control source for the Base module.
Address	001-xxx	Set the DMX address for the Base module.
Universe	000-255	When using Art-Net or sACN control source, set the universe.

Navigate: Main Menu → Address → Macro Module

The Macro (Flex) module is an optional feature. Select **Disable** in the Mode menu to turn off the module.

Settings	Value	Description
Mode	<ul style="list-style-type: none">• Independent• Compound• Disable	Select how the Macro (Flex) module is implemented: <ul style="list-style-type: none">• Compound - the module inherits its settings from the Base module. See the Source, Address, and Universe settings for details.• Independent - the addressing and control of the module are independent of the other modules.• Disable - the module is off. The default mode is Compound.
Source	<ul style="list-style-type: none">• DMX• Art-Net• sACN	Select the control source for the Macro (Flex) module. Note: This option is only available when the Mode selection is set to Independent . When you set the module to Compound mode, the Source is inherited from the Base module.
Address	001-xxx	Set the DMX address for the Macro (Flex) module. Note: This option is only available when the Mode selection is set to Independent . When you set the module to Compound mode, the Address is inherited from the Base module Address (Base module Address+20).
Universe	000-255	When using Art-Net or sACN control source, set the universe. Note: This option is only available when the Mode selection is set to Independent . When you set the module to Compound mode, the Universe setting is inherited from the Base module.

Navigate: Main Menu → Address → Pixel Module

The Pixel module is an optional feature. Select **Disable** in the Mode menu to turn off the module.

Settings	Value	Description
Mode	<ul style="list-style-type: none"> • Independent • Compound • Disable 	<p>Select how the Pixel module is implemented:</p> <ul style="list-style-type: none"> • Compound - the module inherits its settings from one of the other modules. See the Source, Address, and Universe settings for details. • Independent - the addressing and control of the module are independent of the other modules. • Disable - the module is off. <p>The default mode is Disable.</p>
Source	<ul style="list-style-type: none"> • DMX • Art-Net • sACN 	<p>Select the control source for the Pixel module.</p> <p>Note: This option is only available when the Mode selection is set to Independent. When you set the module to Compound mode, the Source is inherited from the Macro (Flex) module (or the Base module if the Macro (Flex) module is disabled).</p>
Address	001-xxx	<p>Set the DMX address for the Pixel module.</p> <p>Note: This option is only available when the Mode selection is set to Independent. When you set the module to Compound mode, the Address is inherited from the Macro (Flex) module Address (Macro (Flex) module Address+15). If the Macro (Flex) module is disabled, then the Address is inherited from the Base module Address (Base module Address+20).</p>
Universe	000-255	<p>When using Art-Net or sACN control source, set the universe.</p> <p>Note: This option is only available when the Mode selection is set to Independent. When you set the module to Compound mode, the Universe setting is inherited from the Base module.</p>

Example Use Cases

Default Use Case

The system has a small number of fixtures and limited universes of DMX, so numerous channels of DMX cannot be dedicated to each individual fixture.



Example:

For each fixture:

- Configure the Base module with DMX source and a unique address.
- Use the default settings for the Macro (Flex) and Pixel modules:
 - Macro (Flex) module set to Compound mode
 - Pixel module set to Disable mode

The result: All fixtures have 35 channels of control for Base module functions and Macro (Flex) module animations. The recommended console library is Base + Flex.

Many Universes of DMX Controlled by a Console

The system has many universes of DMX available, so 63 channels of DMX can be dedicated to each individual fixture.



Example:

For each fixture:

- Configure the Base module with DMX source and a unique address.
- Set both the Macro (Flex) and Pixel modules to Compound mode.

The result: All fixtures have 63 channels of control for Base module functions, animations, and pixels. The recommended console library is Base + Flex + Pixel.

Limited Universes of DMX with Individual Control

The system does not have enough DMX to dedicate 35 channels of DMX to each fixture, but individual control of each fixture is necessary.



Example:

For each fixture:

- Configure the Base module with DMX source and a unique address, for example:
 - Fixture 1 = address 1
 - Fixture 2 = address 21
 - Fixture 3 = address 41
 -
 -
 - Fixture 24 = address 461
- Configure the Macro (Flex) module with the Independent mode and an address that is common for all fixtures (address 481 in this example).

The result: You can control each fixture individually and you can access the Flex effects (although all fixtures will perform the same animation). The recommended console libraries are Base for each unique fixture and a single instance of Flex for the Flex/Macro control.

Separate Console Control and Video Server Control

The system contains a video control source in addition to a DMX console.



Example:

For each fixture:

- Configure the Base module with DMX source and a unique address.
- Set the Macro (Flex) module to Compound mode.
- Set the Pixel module to Independent mode, set the sACN or Art-Net source, and assign a unique DMX address and universe.

The result: All fixtures have control for the 35 channels of Base module functions and animations via DMX, and 28 channels of control for the Pixel module via Ethernet from a video server.

Info Menu

Set the Time Information

Navigate: Main Menu → Info → Time Info

Parameter	Value	Description
Current Time	XXXX (Hours)	Running time of the fixture from the last time that the fixture was powered on, shown in hours (h). The counter resets after the fixture is turned off.
Ttl Life Hrs	XXXX (Hours)	Total running time of the device, shown in hours (h).
Last Run Hrs	XXXX (Hours)	Running time of the fixture from the last time that the run time value was reset, shown in hours (h).
LED Hours	XXXX (Hours)	Total running time of the fixture LEDs, shown in hours (h).
Timer PIN	Timer PIN XXX	You must enter the Timer PIN in order to access the Clr Last Run menu item. The default Timer PIN is 038.
Clr Last Run	<ul style="list-style-type: none">• ON• OFF	This password-protected menu item resets the Last Run Hrs value. You must enter the Timer PIN to access this menu item. Select ON to clear the value for the Last Run Hrs parameter for the fixture.
LED Time PIN	LED Time PIN XXX	You must enter the LED Time PIN in order to access the Clear LED Time menu item. The default LED Time PIN is 038.
Clear LED Time	<ul style="list-style-type: none">• ON• OFF	This password-protected menu item resets the LED Hours value. You must enter the LED Time PIN to access this menu item. Select ON to clear the value for the LED Hours parameter.

View Fixture Errors

Navigate: Main Menu → Info → Error Info

Displays any current fixture errors. See [Error Codes on page 30](#) for information about the errors.

View DMX Values for Channels

Navigate: Main Menu → Info → DMX Value

View the DMX value of each of the fixture's channels (parameters of the fixture). Scroll to the parameter that you want to view (Pan, Tilt, etc.) and view the value. The DMX value that you view is the DMX value that displays on the main window of the UI until you select a different DMX value to view.

View Fixture Head Temperature

Navigate: Main Menu → Info → Head Temp

Displays the current fixture temperature as read from the fixture head (near the CMY filter).

View Power Temperature

Navigate: Main Menu → Info → Power Temp

Displays the current temperature as read from the power supply in the fixture base, which can help you to determine if the power supply is overheating.

View Fan Speeds

Navigate: Main Menu → Info → Fan Speed

Displays the speeds of the fixture's fans (in RPM).

View Ethernet IP Address

Navigate: Main Menu → Info → Ethernet IP

Displays the Ethernet IP address for the fixture. You can modify this value in the Set menu. See [Access Service Settings on page 25](#).

View Software Version

Navigate: Main Menu → Info → Software Ver

Displays the software version for the fixture.

Set Menu

Set the Status Options

Navigate: Main Menu → Set → Status

Parameter	Value	Description
Pan Reverse	<ul style="list-style-type: none">• ON• OFF	Reverse the pan movement of the fixture. The default value is OFF.
Tilt Reverse	<ul style="list-style-type: none">• ON• OFF	Reverse the tilt movement of the fixture. The default value is OFF.
Pan Degree	<ul style="list-style-type: none">• 630• 540	Change the pan rotation of the fixture from the default setting of 540 degrees to 630 degrees.
Encoders	<ul style="list-style-type: none">• ON• OFF	Turn on or off the encoder feedback for pan and tilt movement. You may want to turn off encoders when working on a fixture so that you can move pan and tilt without the fixture automatically moving back to position.
Hibernation	<ul style="list-style-type: none">• OFF• 1–99 minutes	Hibernation mode forces the LEDs and stepper motors to power off when the fixture loses DMX control signal for a set period of time. The default time setting is 15 minutes.
Refresh Rate	<ul style="list-style-type: none">• 2.4 kHz• 16 kHz	Set the refresh rate of the fixture. The higher 16 kHz setting creates a beam with less "strobing" on camera, but it is noisier than the 2.4 kHz setting.
P/T Home Mode	<ul style="list-style-type: none">• Standard• Tilt First• Pan First	Set the order in which pan and tilt homing is performed. <ul style="list-style-type: none">• Standard: the pan and tilt home procedures run simultaneously.• Tilt First: the tilt home procedure runs to completion, then the pan home procedure begins.• Pan First: the pan home procedure runs to completion, then the tilt home procedure begins.
Dim Control	<ul style="list-style-type: none">• Master Base Intensity• Independent Base Intensity	Set the modules to which the Dimmer DMX channel is applied. <ul style="list-style-type: none">• Master Base Intensity: the Dimmer DMX channel is applied to the Base, Macro (Flex), and Pixel modules.• Independent Base Intensity: the Dimmer DMX channel is applied only to the Base module.

Access Service Settings

Navigate: Main Menu → Set → Service Setting

Parameter	Value	Description
Service PIN	Service PIN XXX	You must enter the Service PIN in order to access the other Service Setting parameters. The default Service PIN is 050.
RDM UID	RDM UDIs for each module	<p>This password-protected menu item lets you modify the RDM UID. You must enter the Service PIN to access this menu item.</p> <p>Each module has a unique RDM UDI that consists of the manufacturer ID and a randomly generated number.</p> <p>Note: Remote Device Management (RDM) requires that all RDM devices have a unique identifier (UID). Modifying this setting can break the RDM capability of this fixture.</p> <p>Duplicate RDM UDIs on the same DMX control run will result in a data collision, causing a communication failure. Ensure that all fixtures have a unique RDM UID if RDM functionality is to be used.</p> <p>If DMX splitters are used and RDM control is to be used, these splitters must support RDM.</p>
Ethernet IP	XXX.XXX.XXX.XXX	<p>This password-protected menu item lets you modify the IP address. You must enter the Service PIN to access this menu item.</p> <p>The default IP address is 002.142.058.034.</p>
Ethernet Mask IP	XXX.XXX.XXX.XXX	<p>This password-protected menu item lets you modify the IP subnet mask. You must enter the Service PIN to access this menu item.</p> <p>The default IP subnet mask is 255.000.000.000.</p>
Clr Err Info	<ul style="list-style-type: none"> • ON • OFF 	<p>This password-protected menu item lets you clear error messages after you have fixed the errors. You must enter the Service PIN to access this menu item.</p> <p>Set this parameter to ON in order to clear the error messages. The default setting is OFF.</p>

Set the Fans Mode

Navigate: Main Menu → Set → Fans Mode Setting

Select the fan mode for the fixture:

- Standard
- Studio (reduces fan noise, but decreases fixture output by ~20%)

Set Display Settings

Navigate: Main Menu → Set → Disp. Setting

Parameter	Value	Description
Shutoff Time	02–60 minutes	Enter the amount of time the fixture waits after the last user interface button press until the display goes to sleep. The default value is 5 minutes.
Flip Display	<ul style="list-style-type: none">• ON• OFF	Flip the display 180° when the fixture is mounted vertically. The default value is OFF. Shortcut: With the main UI window displayed, press [>] to flip the display 180°. Press [<] to flip it back to its original orientation.
Key Lock	<ul style="list-style-type: none">• ON• OFF	Lock the user interface. The default value is OFF. To unlock the user interface buttons, press and hold the [MODE/ESC] button for three seconds.

Set the Temperature Scale

Navigate: Main Menu → Set → Temp. C/F

Select the temperature scale for the fixture:

- Celsius (default value)
- Fahrenheit

Update Fixture Firmware Using the USB Port

Navigate: Main Menu → Set → USB Update

Fixture firmware updates are available on the High End Systems, Inc. website at highend.com.

1. Save the firmware update file to a USB drive.
2. Insert the USB drive in the fixture base (see [Fixture Overview on page 5](#) for the USB port location).
3. On the **Main Menu**, select **Set → USB Update**. The fixture reads the USB drive and displays a list of any firmware update files on the USB drive.
4. Select the appropriate file and then press the [Enter] button.
5. The software prompts you to confirm the update with the message "Update fixture?" Use the navigation buttons to select "Yes," and then press the [Enter] button.
 - The firmware update begins. A progress monitor shows you the progress of the update.
 - The fixture restarts when the update is complete, and the fixture performs a data check to verify the update.
 - The firmware update is complete when the display returns to its default state.
6. Remove the USB drive from the fixture.

Reset Fixture to Factory Default Settings

Navigate: Main Menu → Set → Reset Default

Select ON to reset the fixture to the factory default settings.

Test Menu

Reset (Home) the Mechanical Positions on the Fixture

Navigate: Main Menu → Test → Home

Reset ("home") all features on the fixture, including, pan, tilt, colors, gobos, etc.

Test the Fixture

Navigate: Main Menu → Test → Self Test

Run a self-test program on the fixture. When you run the test, the display indicates "Running" and the fixture automatically runs a self-test procedure, testing each of the functions. Press [MODE/ESC] button to end the self-test and return the display to the previous menu.

Test an Individual Channel

Navigate: Main Menu → Test → Test Channel

Run a self-test program on individual channels. The default value is Control. Select a different channel to run a self-test on that channel.

Manually Set an Individual Channel

Navigate: Main Menu → Test → Manual Ctrl.

Select an individual channel on the fixture and manually set the channel value. While in Manual Control mode, all effects are canceled, the shutter opens, and the dimmer intensity is set to 100%.

Re-Calibrate an Individual Feature

Navigate: Main Menu → Test → Calibration

Please contact technical support at High End Systems, Inc. before using this parameter. See [Contacting High End Systems on page 1](#).

You must enter the Calibration PIN in order to access the Calibration menu items. The default Calibration PIN is 050.

Once you have accessed the Calibration menu, select an individual feature on the fixture and manually calibrate it to a new "home" setting.

Preset Menu

Set the Playback Settings

Navigate: Main Menu → Preset → Play Back

Playback settings allow you to run an Auto Program as a Master fixture or in stand-alone mode, or to receive playback information from a different Master fixture.

Preset programming requires one fixture to act as the Master. All other SolaPix 7 fixtures that are connected to the designated Master fixture can then receive Auto Programs from the Master fixture.



Example: You edit groups of scenes into Programs 1–10 on the Master fixture.

- Program 2 is assigned to Part 1
- Program 4 is assigned to Part 2
- Program 6 is assigned to Part 3

- * Fixtures assigned as Slave 1 will play back Part 1
- * Fixtures assigned as Slave 2 will play back Part 2
- * Fixtures assigned as Slave 3 will play back Part 3

Select the appropriate playback setting:

- DMX Control: Return the fixture to DMX control from another playback mode.
- Set To Slave: Fixture will play back the Auto Program that is defined on the Master fixture.
- Auto Program: Fixture runs an Auto Program either in stand-alone mode or as a Master fixture. Use the Select Prog parameter to select the program (see [Select an Auto Program below](#)).

Select an Auto Program

Navigate: Main Menu → Preset → Select Prog.

Select the Auto Program that the fixture will run either in stand-alone mode or as a Master fixture.

Program	Range	Default Value
Prog. Part 1	Program 1–Program 10	Program 1
Prog. Part 2	Program 1–Program 10	Program 2
Prog. Part 3	Program 1–Program 10	Program 3

Edit an Auto Program

Navigate: Main Menu → Preset → Edit Program

Create the Auto Program that the fixture will run either in stand-alone mode or as a Master fixture (see [Select an Auto Program above](#)).

Navigate to the Auto Program that you want to edit (Program 1, Program 2, etc.), and then set the scene (SC001, SC002, etc.) for each step (Step 01, Step 02, etc.) in the Auto Program. You can set a maximum of 64 steps. The SolaPix 7 fixture provides 250 pre-programmed scenes, or you can customize scenes using the Edit Scenes parameter (see [Edit a Scene or Capture \(Record\) a Scene on the facing page](#)).

Edit a Scene or Capture (Record) a Scene

Navigate: Main Menu → Preset → Edit Scenes

The SolaPix 7 fixture provides 250 pre-programmed scenes that you can use or edit to build an Auto Program. Each scene is a snapshot of a set of fixture parameters (for example, color, beam quality and pattern, intensity, focus, etc.) that you can assign to a step in an Auto Program. Select the scene (Scene 001, Scene 002, etc.) that you want to edit, and then set the parameters for the scene or capture the parameters for the scene from the current DMX input.

In addition to standard SolaPix 7 features (pan, tilt, etc.), scene parameters include the following options.

Parameter	Value	Description
Fade Time	0–255 seconds	Enter the crossfade time applied to parameters when the scene plays.
Scene Time	0.2–99.9 seconds	Enter how long the scene will play before the next scene plays. The default value is 0.3 seconds.
Input By Out		Capture the parameter values for the scene from the current DMX input.

Capture (Record) Multiple Scenes

Navigate: Main Menu → Preset → Scenes Input

You can capture DMX data and record those parameters as a series of scenes. Select the start and end scene numbers for the range of scenes that you want to record. The fixture records the incoming DMX data into the selected scenes, with each change in DMX data triggering the next scene in the range. When all scenes in the range have been recorded, the display returns to the main menu.



Note: *While capturing the DMX data, the SolaPix 7 fixture does not play back the DMX input; it only captures the data. You must edit or play back the scene after recording is complete to verify the results. We suggest that you prepare the scenes on a DMX controller with a zero crossfade for all parameters between steps. Remember that any change of a DMX value will automatically advance to the next scene during capture.*

Error Codes

When you apply power to the fixture, it runs a calibration (homing) sequence and displays any errors that it detects.

This message displays after the reset of the fixture if any of the following conditions exist:

Pan Coarse

This message displays after the reset of the fixture if any of the following conditions exist:

- the yoke's magnetic-indexing circuit malfunctions (optical or magnetic sensor failure)
- the stepper motor is defective or the related IC driver on the main PCB has failed
- the Pan movement is not located in the default position after the reset

Tilt Coarse

This message displays after the reset of the fixture if any of the following conditions exist:

- the fixture head magnetic-indexing circuit malfunctions (optical or magnetic sensor failure)
- the stepper motor is defective or the related IC driver on the main PCB has failed
- the Tilt movement is not located in the default position after the reset

Zoom Wheel

This message displays after the reset of the fixture if any of the following conditions exist:

- the magnetic-indexing circuit malfunctions (optical or magnetic sensor failure)
- the stepper motor is defective or the related IC driver on the main PCB has failed
- the Zoom movement is not located in the default position after the reset

Cleaning and Maintenance



CAUTION: *Disconnect the fixture from mains power before starting any maintenance procedures.*

Keep the following in mind during regular service and inspection:

- All screws for installing the device or parts of the device must be tightly connected and must not be corroded.
- There must not be any deformations to the housing, lenses, rigging, and installation points (ceiling, suspension, trussing).
- Moving parts must not show any signs of wear and must move smoothly without issue.
- The power supply cables must not show any damage, material fatigue, or sediment.
- If spare parts are required, order only genuine parts from your local authorized dealer.

To ensure that the device remains in good working condition and does not fail prematurely, regular maintenance is recommended.



CAUTION: *The backside of each lens in the SolaPix 7 fixture is coated with a HazeFree lens coating technology (patent pending) that keeps the lens clear when the fixture is used with theatrical haze. Use of paper toweling or other abrasive, high-friction wipes and ammonia-based glass cleaners may permanently damage the coating.*

If the lens coating wears away, contact High End Systems, Inc. Technical Services for assistance.

1. Clean the lens only when necessary, and only use a Silky Microfiber Optical Cloth with purified water or an ammonia-free glass cleaner such as Miller Stevenson MS-260 Glass Cleaner.
2. Clean the fans regularly to ensure maximum airflow and efficient cooling. This will ensure that the light source operates in the best possible condition.

HIGH END SYSTEMS



an **ETC** Company

Headquarters ■ 2105 Gracy Farms Lane, Austin, TX, 78758 USA ■ Tel +512 836 2242 ■ Fax +512 837 5290
Global Offices ■ London, UK ■ Holzkirchen, DE ■ Hong Kong

Web highend.com ■ **Support** support.etcconnect.com/HES

© 2019 Electronic Theatre Controls, Inc. ■ Product information and specifications subject to change.

ETC intends this document to be provided in its entirety. ■ Trademark and patent info: etcconnect.com/ip

SolaPix 7 User Manual Rev A Released 2019-12